



# Aries BGA Adapter Socket

## FEATURES:

- System (adapter and socket combination) converts any BGA device into a PGA on 1.27mm [.050] or 1.50mm [.059] pitch.
- Allows BGA device to be plugged into and removed from application mother board.
- Socket accepts Aries' BGA to PGA adapter, Data Sheet No. 23007.

## SPECIFICATIONS:

- Socket body is UL 94V-0 FR-4.
- Pin body is Brass Alloy 360, 1/2 hard per QQ-B-626.
- 3-fingered collet contact is Beryllium Copper Alloy 172 HT per QQ-C-533 (thru-hole and standard surface mount pin).
- Pin body plating is either 200 $\mu$  [5.08 $\mu$ ] Tin per MIL-T-10727 or 10 $\mu$  [.25 $\mu$ ] Gold per MIL-G-45204 over 100 $\mu$  [2.54 $\mu$ ] Nickel per QQ-N-290.
- Contact plating is 30 $\mu$  [.76 $\mu$ ] Gold per MIL-G-45204 over 50 $\mu$  [1.27 $\mu$ ] Nickel per QQ-N-290.
- Contact current rating=3 Amps.
- Operating temperature=221°F [105°C] Tin plating; =257°F [125°C] Gold plating.
- Insertion Force=45 grams/pin; Withdrawal Force=22 grams/pin; Normal Force=31 grams/pin; based on a .019 [.48] dia. test lead.

## MOUNTING CONSIDERATIONS:

- Suggested PCB hole size=.028 $\pm$ .003 dia.
- Suggested PCB pad size=.040 $\pm$ .003 dia.

**ALL DIMENSIONS: INCHES [MILLIMETERS]**

All tolerances  $\pm$  .005 [.13] unless otherwise specified

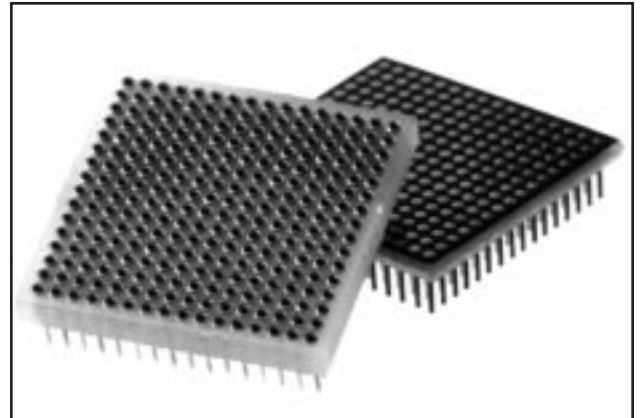

Note: Aries specializes in custom design and production. In addition to the standard products shown on this page, special materials, platings, sizes, and configurations can be furnished, depending on quantities. Aries reserves the right to change product specifications without notice.

## ORDERING INFORMATION

**XXX-BGXXXX-XXX**

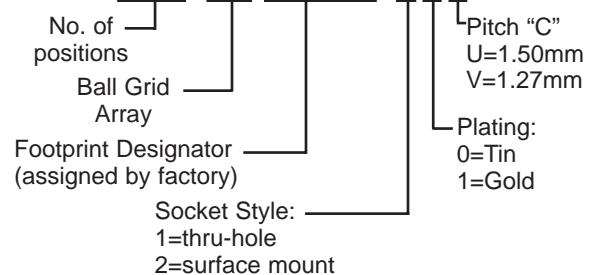

Consult factory for pitch-converting adapter and socket requirements.

Consult Data Sheet No. 23009 for Aries' low-profile surface mount BGA adapter socket.

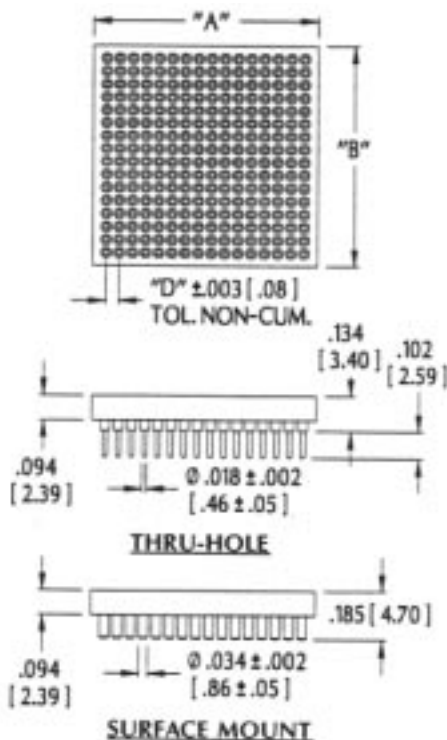

**STRAIGHT THRU ADAPTER & SOCKET MATING HEIGHTS**

**PITCH-CONVERTING ADAPTER & SOCKET MATING HEIGHTS**

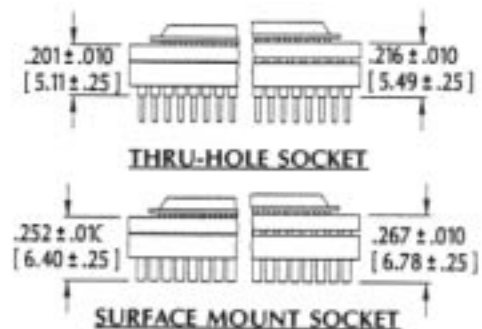

**ARIES**  
ELECTRONICS, INC.  
http://www.arieselec.com • info@arieselec.com

**NORTH AMERICA**  
Frenchtown, NJ USA  
TEL: (908) 996-6841  
FAX: (908) 996-3891



**UK/IRELAND/GB**  
TEL: +44 870 240 0249  
FAX: +44 1653 600493  
uking@arieselec.com

**EUROPE/MAINLAND/HOLLAND**  
TEL: +31 78 615 94 65  
FAX: +31 78 615 43 11  
europe@arieselec.com

23008  
REV.B