



# HIGH FREQUENCY INTERPOSER SOCKET

## FEATURES:

- Pressure mount plunge to board interposer.
- Multiple configurations: MLF, QFN, CSP, BGA, MSOP, QSOP, QFP and more.
- Very low inductance per contact site.
- High cycle life with easy maintenance.
- Manual or Automated Handler applications.
- High Frequency Application: ~1.0dB to 40GHz (0.5mm pitch).

## SPECIFICATIONS:

- Socket body material: Specified at time of quotation.
- Interposer: Etched Kapton with Gold Plated Pads and compliant pads on bottom side.
- Available pitches down to 0.32mm.
- Contact self-inductance: 0.11nH (0.50mm pitch CSP).
- VSWR <2:1 to 40Ghz
- Contact resistance: <20milliohm.
- Contact force: 15 - 25 grams.
- Current Capacity: 5 Amps.
- Contact life: 50,000 - 100,000.
- Signal Path Length: 0.011" (with compliant pads).
- Mutual capacitance: 0.015pF

## MOUNTING CONSIDERATIONS:

- Suggested PCB pads - Gold Plated.
- Mounting force - 5oz. inches (0.035Nm)

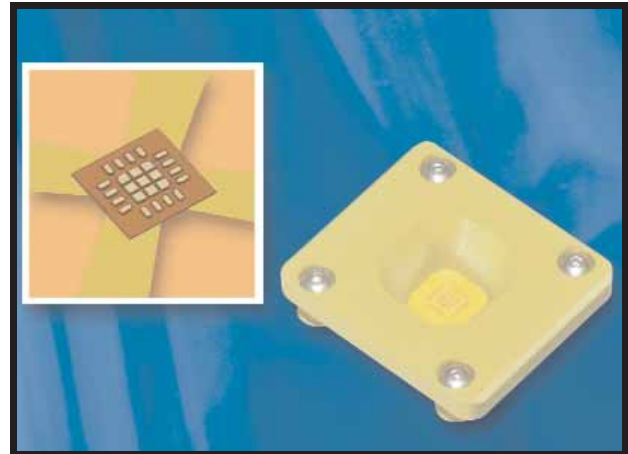

*Note: Aries specializes in custom design and production. In addition to the standard products shown on this page, special materials, platings, sizes, and configurations can be furnished, depending on quantities. Aries reserves the right to change product specifications without notice.*

## ORDERING INFORMATION

CONSULT FACTORY

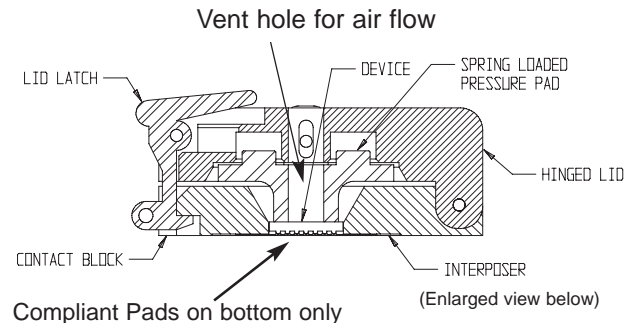
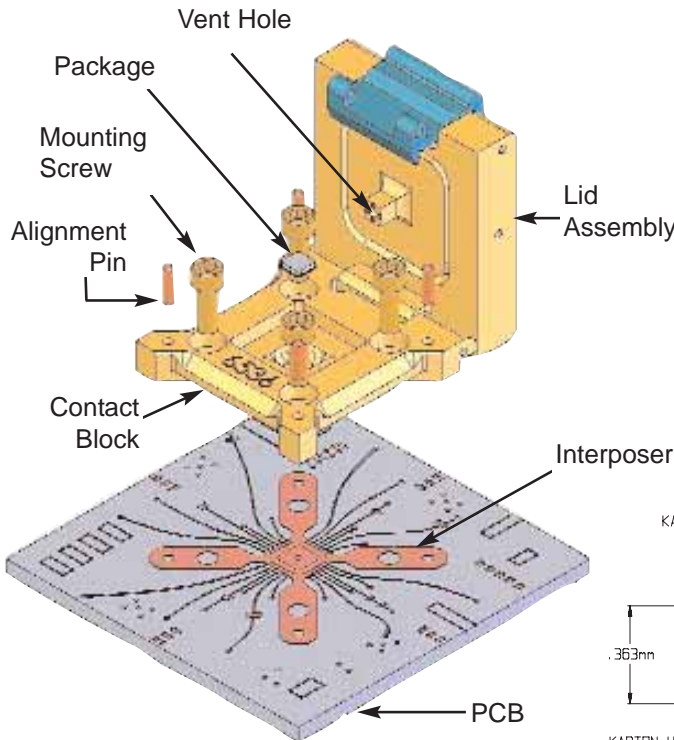

ALL DIMENSIONS: INCHES [MILLIMETERS]

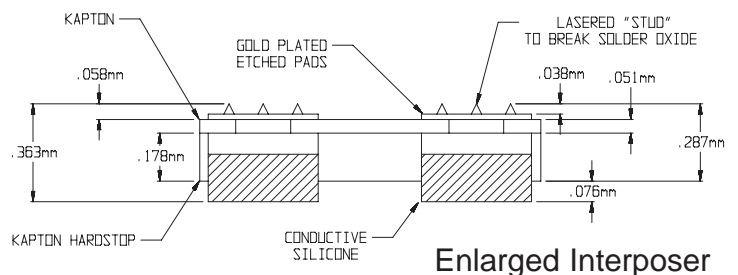

**ARIES**  
ELECTRONICS, INC.  
<http://www.arieselec.com> • [info@arieselec.com](mailto:info@arieselec.com)

**NORTH AMERICA**  
Frenchtown, NJ USA  
TEL: (908) 996-6841  
FAX: (908) 996-3891



**EUROPE**  
TEL: +44 870 240 0249  
FAX: +44 871 919 6033  
[europa@arieselec.com](mailto:europa@arieselec.com) 24007  
REV.1